

PLAN VIEW

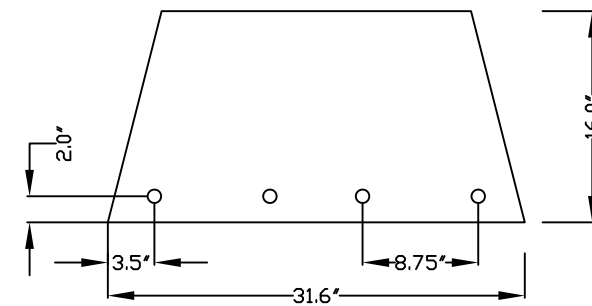

1 CC-180 BLOCK UNITS
NOT TO SCALE

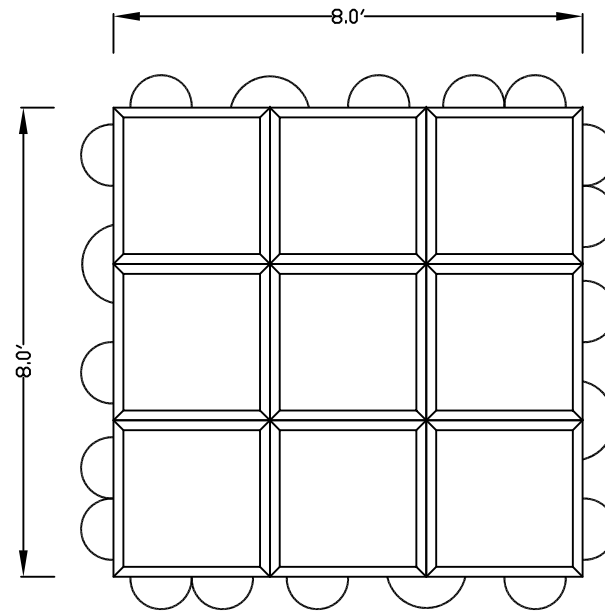

2 CC-180 MATTRESS
NOT TO SCALE

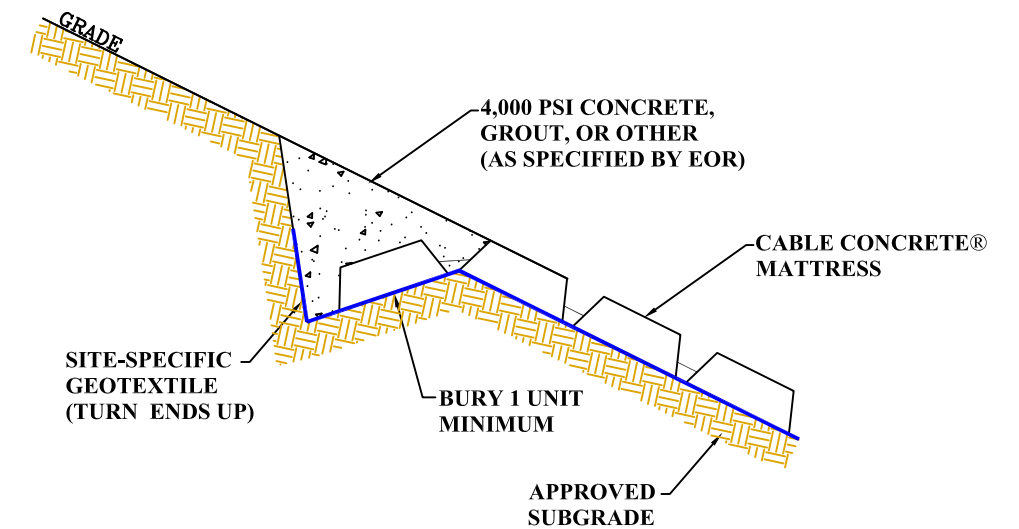

3 TOP TERMINATION
NOT TO SCALE

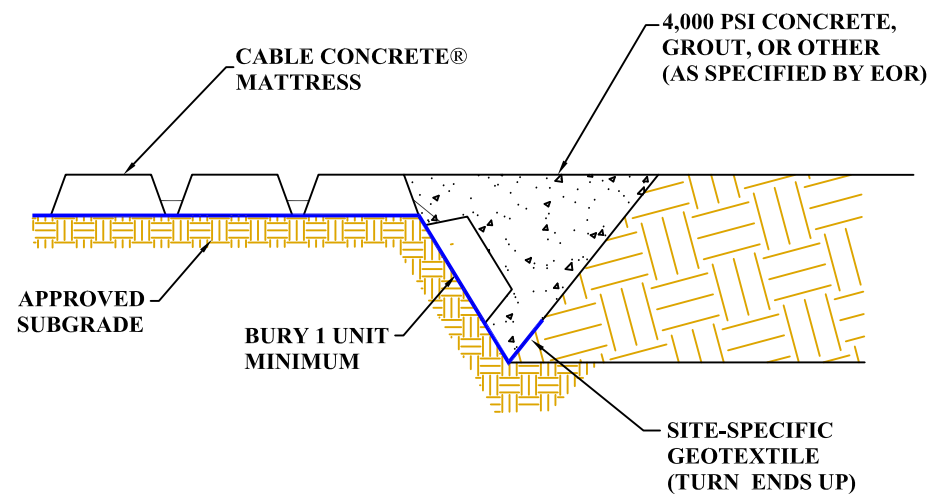

4 FLANK TERMINATION
NOT TO SCALE

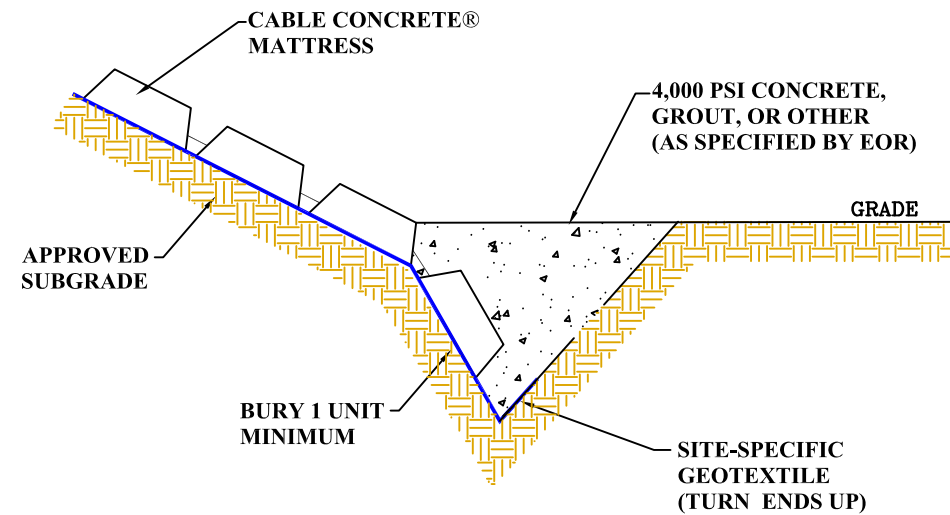

5 TOE TERMINATION
NOT TO SCALE

The design and information depicted in this drawing is provided as a service to the project owner, engineer, and the contractor by International Erosion Control Systems ("IECS"). Neither this drawing, nor any part thereof, may be used, reproduced or modified in any manner without the prior written consent of IECS. Failure to comply is done at the user's own risk and IECS expressly disclaims any liability or responsibility for such use.

If discrepancies between the supplied information upon which the drawing is based and actual field conditions are encountered as site work progresses, these discrepancies must be reported to IECS immediately for re-evaluation of the design. IECS accepts no liability for designs based on missing, incomplete or inaccurate information supplied by others.

International Erosion Control Systems, Inc.

www.iecsusa.com

3030 N. Rocky Point Drive, Suite 150, Tampa FL 33607

855-768-1420

855-768-1425 FAX



MARK:	DATE:	REVISION DESCRIPTION:	BY:

Cable Concrete
CC 180
STANDARD TERMINATION and
CONNECTION DETAILS

PROJECT #:	DATE:
-----	9/5/2019
DESIGNED BY:	DRAWN BY:
-----	MDD
CHECKED BY:	APPROVED BY:
-----	DD
SHEET #:	CC1 OF CC2

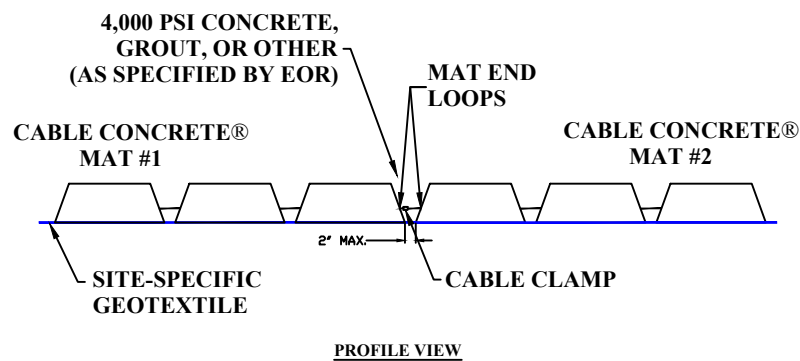

WHEN PLACING THE MATS, THE GAP BETWEEN THE MATS SHOULD NOT BE ANY LARGER THAN A 2" MAXIMUM. IF THE MATS ARE PLACED WITH A LARGER SPACE THAN 2", IT IS RECOMMENDED TO PLACE 4,000 PSI CONCRETE, GROUT, OR OTHER (AS SPECIFIED BY EOR) IN THE SEAM BETWEEN THE MATS.

6 CABLE CLAMP / MAT CONNECTION DETAIL
NOT TO SCALE

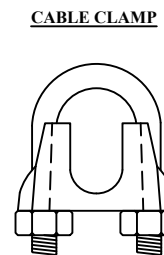
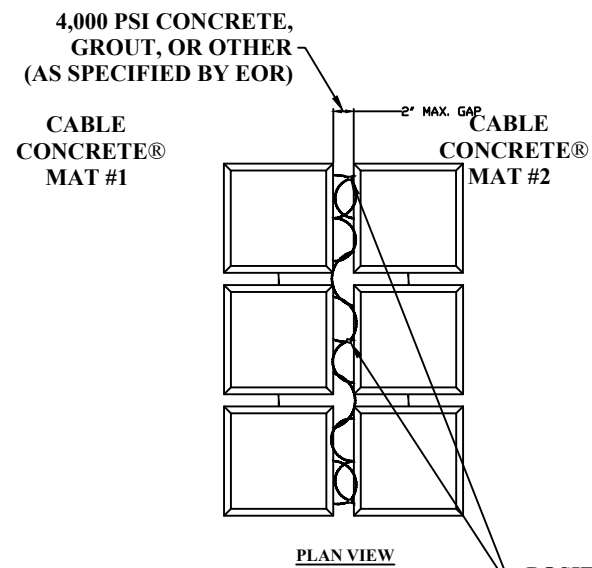

NOTE: CABLE CLAMPS ARE MADE OF A U-BOLT, A COVER SADDLE, AND TWO NUTS.

POSITION CABLE CLAMP, AT 4FT ON-CENTER INTERVALS, AS SNUG TO THE BASE OF THE CONCRETE BLOCK AS POSSIBLE, BY SLIDING CABLE CLAMP DOWN TO THE ADJACENT LOOPS, THEN TIGHTEN CLAMP SECURELY.

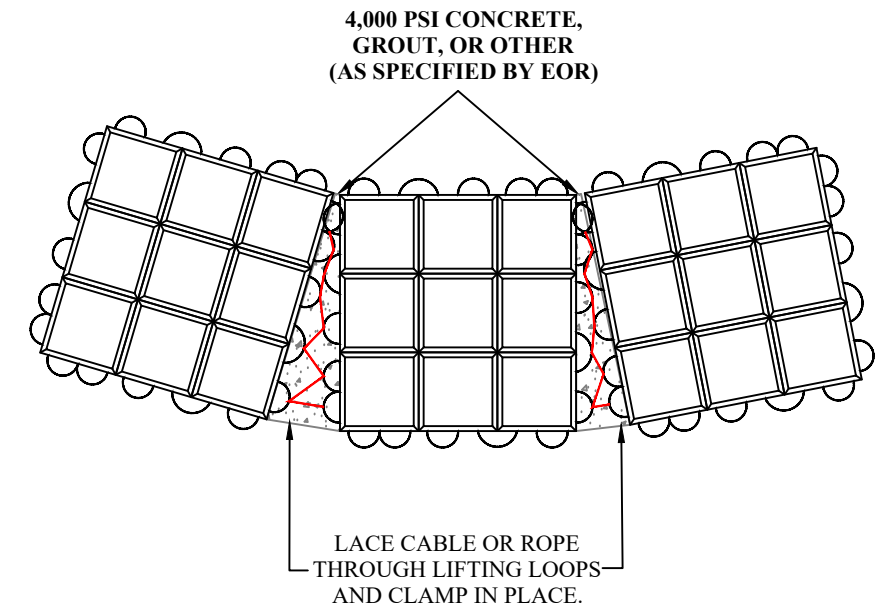

7 WEDGE GAP MAT TO MAT CONNECTION DETAIL
NOT TO SCALE

The design and information depicted in this drawing is provided as a service to the project owner, engineer, and the contractor by International Erosion Control Systems ("IECS"). Neither this drawing, nor any part thereof, may be used, reproduced or modified in any manner without the prior written consent of IECS. Failure to comply is done at the user's own risk and IECS expressly disclaims any liability or responsibility for such use.

If discrepancies between the supplied information upon which the drawing is based and actual field conditions are encountered as site work progresses, these discrepancies must be reported to IECS immediately for re-evaluation of the design. IECS accepts no liability for designs based on missing, incomplete or inaccurate information supplied by others.

International Erosion Control Systems, Inc.

www.iecsusa.com

3030 N. Rocky Point Drive, Suite 150, Tampa FL. 33607
855-768-1420 855-768-1425 FAX



MARK:	DATE:	REVISION DESCRIPTION:	BY:

Cable Concrete
CC 180

STANDARD TERMINATION and
CONNECTION DETAILS

PROJECT #:	DATE:
-----	9/5/2019
DESIGNED BY:	DRAWN BY:
-----	MDD
CHECKED BY:	APPROVED BY:
-----	DD
SHEET #:	
CC2	OF CC2